

Flexural and fatigue behavior of prestressed concrete beams made with portland pozzolana cement

V.V. Arora*, Brijesh Singh and Lalit Yadav

(Received: December 31, 2015; Accepted: May 9, 2016; Published online: July 05, 2016)

Abstract: There is rapid growth of Portland Pozzolana Cement (PPC) production over the last few years. The use of PPC has been included by Indian and international standards/specifications in the past. But in India, the use of PPC for prestressed concrete (PSC) is generally not recommended in different specifications due to apprehension of late strength development and a lack of data on other critical properties of PSC like creep, shrinkage, and fatigue. The critical properties affecting PSC structures such as strength, modulus of elasticity, drying shrinkage, and creep as studied in the past by NCB are at par in case of available PPC when compared with ordinary portland cement (OPC). The present study is carried out to evaluate the flexural and fatigue behavior of PSC beams made with OPC and PPC. The study was conducted on M40 grade concrete using two locally available Indian cements, i.e. OPC and PPC. The test results of flexural strength test conducted on PSC beams indicate that flexural behavior for both OPC and PPC made PSC beams are similar. Based on fatigue studies, it is seen that the fatigue effects are also similar in case of both OPC and PPC made concrete. During flexure testing without fatigue, it was observed that the first cracking load is slightly lower in case of PPC but ultimate load is almost equal in PPC and OPC. Fatigue test results of PSC beams are similar for both OPC and PPC made concrete.

Keywords: fatigue, flexure, ordinary Portland cement, Portland pozzolana cement, prestressed.

1. Introduction

Fatigue is a process of progressive permanent internal changes in the materials that occur under the actions of repetitive loadings. Small flaws or discontinuity are present internally or on the surface of body. At these flaws, stresses are very high due to stress concentration effects. As a result, under the cyclic loadings, cracks can grow at these flaws due to plastic deformations even if applied normal stresses are lower than the elastic limit. This can result in abrupt failure of the material. Concrete under compression suffers tensile stress or strain due to lateral expansion [1].

Most of the concrete structures nowadays are reinforced ones in which steel reinforcement is used to offset the low tensile strength of concrete, and the steel reinforcement provides the cracked concrete beam with flexural strength. It does not prevent cracking and loss of stiffness due to cracking. Prestressed concrete (PSC) is a particular form of

concrete in which prestressing involves the application of initial compressive load on a structure to reduce or eliminate the internal tensile forces developed due to working loads and thereby control or eliminate cracking. The initial compressive load is imposed and sustained by highly tensioned steel reinforcement reacting on the concrete.

In recent times, there has been more attention towards the fatigue behavior of high strength concrete subjected to fatigue loading because of its increased usage in structures such as bridges, offshore structures, and reinforced concrete pavements. The critical properties affecting prestressed concrete structures such as compressive strength, modulus of elasticity, drying shrinkage, wear resistance and creep as studied in past by NCB are at par in case of available PPC when compared with OPC [2]. Fatigue failure occurs when a concrete structure fails catastrophically at less than design load after being exposed to a large number of stress cycles [3]. The recovery of deflection after removal of the load was more in case of prestressed beams indicating more elastic behavior. Thus, prestressed beams are more suitable to take fatigue loads than reinforced beams [4]. Unlike flexure of un-prestressed reinforced concrete beams, which can be designed to fail due to steel reinforcement yielding, the flexural failure

Corresponding author V.V. Arora is a Joint director, National Council for Cement and Building Materials, Haryana, India.

Brijesh Singh is a manager, National Council for Cement and Building Materials, Haryana, India.

Lalit Yadav is a deputy manager, National Council for Cement and Building Materials, Haryana, India.

of prestressed beams is brittle. Although flexural failure of prestressed beams can be caused by yielding of the prestressing steel, the usual cause is compression crushing of concrete. This research is intended to expand the knowledge concerning the flexural performance of PSC made with Ordinary Portland Cement (OPC) and Portland Pozzolana Cement (PPC). The flexural and fatigue studies carried out using PSC beams made with OPC and PPC on M40 grade of concrete based on 28 days cube compressive strength as per Indian Standard IS: 456-2000 included ultimate load testing in flexure on PSC beams under monotonic loading and fatigue load testing in flexure on PSC beams.

2. Experimental data

2.1 Materials

Crushed aggregate with a maximum nominal size of 20 mm was used as coarse aggregate (coarse aggregate 20 mm: 10 mm were used in ratio 60:40) and natural river sand conforming to Zone III as per Indian Standard IS: 383 was used as fine aggregate. OPC and PPC with a fly ash content of 25% were used in this study. Its chemical and physical compositions are given in Table 1. Naphthalene based Rheobuild SP1 for M40 complying with requirements of Indian Standard: 9103–1979 was used throughout the investigation to reduce water demand. Water complying with requirements of IS: 456-2000 for construction purpose was used.

M40 Grade with two different types of cement, i.e. OPC and PPC, was used in this study. The Mix design details of specimens are given in Table 2.

2.2 Mix design details

2.3 Specimen details and testing program

The overall length and the effective span of the beams used for flexural testing were 2.3 m and 2.0 m, respectively. Each beam consisted of a rectangular uniform cross section of 200 x 250 mm (effective depth was 220 mm) throughout the length, and it was longitudinally post-tensioned using four strands placed at each corner of beam in cross section. (two prestressed strands at the bottom and two at the top for holding bearing plate). The strands had diameter of 12.7 mm with ultimate tensile stress of 1570 MPa. The design load of the beam was 50 kN (i.e., calculated theoretical load taking capacity of beam as per IS 1343) with two point loading arrangement with 25 kN at each loading point for comparing the effect of two different types of cement. The PSC beams for this study were designed as per Indian Standard IS: 1343-2012. The Gifford-Udall (CCL) system of post-tensioning was used for anchoring prestressed force. Concrete grade used for the beams was M40. The geometric, reinforcing and prestressing details of all the specimens tested for flexure are shown in Fig. 1. The clear cover to both top and bottom strands was 30 mm.

For studying flexure behavior of PSC beams, two beams each of OPC and PPC were tested, respectively. For studying fatigue behavior of PSC beams, two beams each of OPC and PPC were tested, respectively. The design details of PSC beams are given in Table 3.

Table 1 – Physical, chemical and strength characteristics of cement

Characteristics		OPC	PPC
Physical tests			
Fineness Blaines (m ² /kg) / Specific gravity		309 / 3.15	395 / 2.86
Soundness autoclave / Le Chatelier (%)		0.095 / 2.00	0.084 / 2.00
Initial setting time (min. / max.)		110 / 190	150 / 230
Chemical tests			
Loss on ignition (LOI) (%)		2.72	3.18
Silica (SiO ₂) / iron oxide (Fe ₂ O ₃) (%)		20.35 / 3.48	31.63 / 4.04
Aluminium oxide (Al ₂ O ₃) / calcium oxide (CaO) (%)		4.58 / 60.31	10.54 / 43.22
Magnesium oxide (MgO) (%)		5.25	3.26
Sulphate (SO ₃) / chloride (Cl) (%)		1.92 / 0.028	1.82 / 0.019
Alkalies (%)	Na ₂ O / K ₂ O	0.36 / 0.58	0.28 / 0.60
IR (%)		2.19	27.56
Strength			
3 days (N/mm ²)		35.82	29.80
7 days (N/mm ²)		43.12	41.20
28 days (N/mm ²)		53.00	52.00

Table 2 – Concrete mix design details

w/c	Mix constituents			Fine aggregate, % of total aggregate by weight	28-day average cube compressive strength of concrete on three cubes of 150 x 150 x 150 mm standard size as per IS:456-2000 (N/mm ²)
	Cement type / content (kg/m ³)	Water content (kg/m ³)	Admixture, % by weight of cement (naptha based)		
0.38	OPC / 400	152	1.0	40.0	48.3
0.35	PPC / 434	152	1.0	39.0	48.7

Note: M40A20 Grade; workability 50-75 mm with chemical admixture; moderate exposure condition.

The beam was placed in a simply supported condition over two fixed steel pedestals to obtain a clear span of 2,000 mm. Loading setup was made for four points bending by placing a distributor beam over two roller supports at one-third span distance from supports. The testing setup along with instrumentation details are shown in Fig. 2.

Hydraulic actuator of 500-kN capacity was used for application of the monotonic loading in displacement control at mid-span of the beam. All strain gages and LVDTs were connected to the high

precision data acquisition system. The load and displacement applied during loading were recorded by the control unit of the actuator as well as by the data acquisition system. The testing program using OPC and PPC on M40 grade of concrete included ultimate load testing in flexure on PSC beams under monotonic loading and fatigue load testing in flexure on PSC beams. Fatigue testing in compression was also carried out, and the test results of same are discussed in next paragraph.

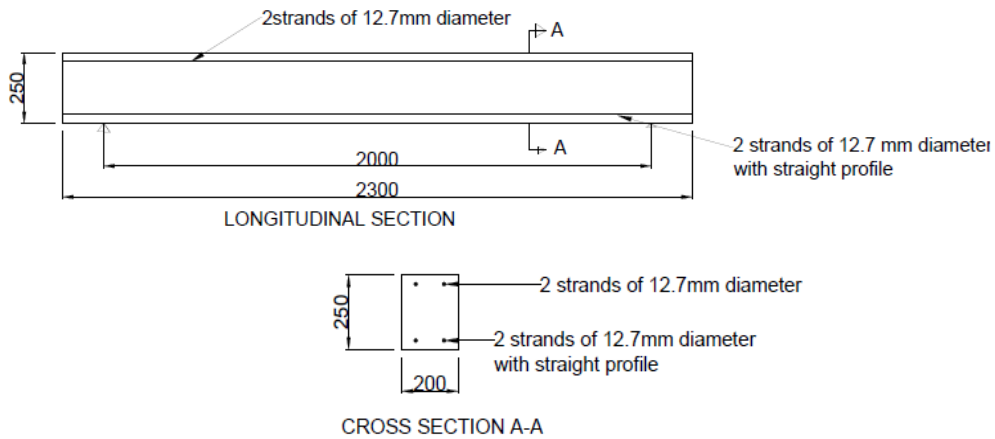

Fig. 1 – Elevation and section of beams tested for flexure

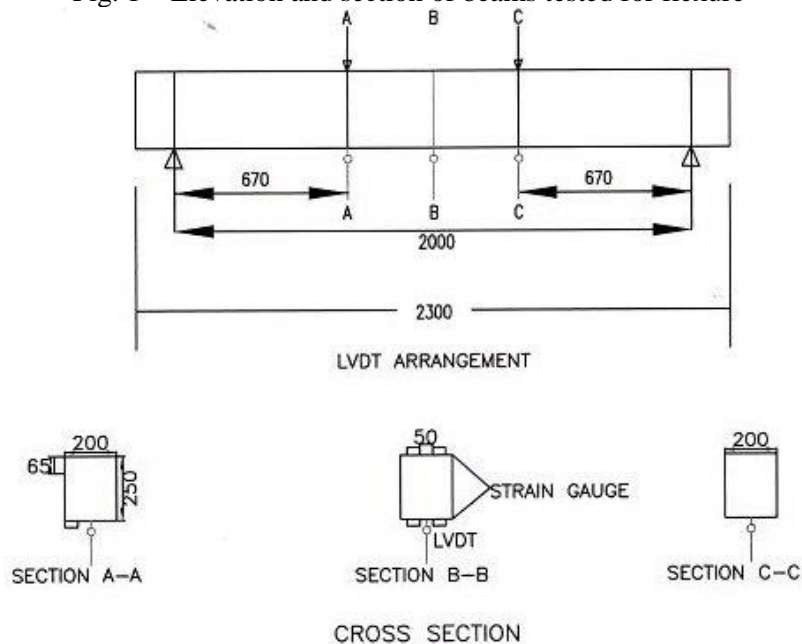

Fig. 2 – Testing setup along with instrumentation details

Table 3 – Prestressing details for post-tensioned prestressed beams

Grade of concrete	M40
Cross-sectional dimension, (b) x (h)	200 mm x 250 mm
Characteristic strength of prestressing wires	1780 N/mm ² as per IS:14268-1995
Loading type	Two point load
Limiting value of ultimate prestressing force	396 kN (total)
Number of wires and diameter of wires	Two strands of 12.70-mm diameter
Span / type of support	2 m / simply supported
Camber	65.00 mm at mid span
Total deflection	-1.07 mm
Initial prestressing force	248 kN (total)
Allowable tensile stress at transfer and service condition	3 N/mm ²

3. Results and discussions

3.1 Flexural strength

The post-tensioned PSC beams of size 200 x 250 x 2,300 mm and M40 grade concrete were cast for flexural tests. The post-tensioned prestressed beams were designed for two points loading of 25 kN each. The concrete mix design details for M40 grade concrete were as per mix design details given in Table 2. For flexural strength assessment, flexural testing machine of 500-kN capacity having displacement rate control facility was used. Keeping in view the specimen size to be tested and failure load, the loading was decided to be applied at the rate of 0.2 mm/min in displacement control (Fig. 3). The beams failed due to widening and extending of flexural cracks into compression zone and crushing of concrete in the compression zone, between the loading points. No shear cracks in the shear zone and no damage at the anchorage zone of the beams were observed.

The results of flexural test conducted on PSC beams indicated that flexural behavior for both

OPC and PPC made concrete are similar. The first cracking load for both OPC and PPC beams were almost same with deflections in the range of 2–5 mm at mid span, and similarity was observed in ultimate load and ultimate deflections also. The test results are given in Table 4, and graphs and images are shown in Fig. 4.

3.2 Fatigue

3.2.1 Fatigue testing in compression of concrete cylinders

Fatigue test was carried out with a closed loop servo-hydraulic dynamic material testing system (Fig. 5). The minimum stress level of 20–30% was maintained during testing, and fatigue testing was carried out for 1 million cycles. In fatigue tests, sinusoidal loading cycles were loaded in the frequency of 1 Hz which was decided keeping in view the time taken for loading one million cycles. Time taken to load one million cycles was about 12 days.



Fig. 3 – Flexural strength testing arrangement for PSC beams

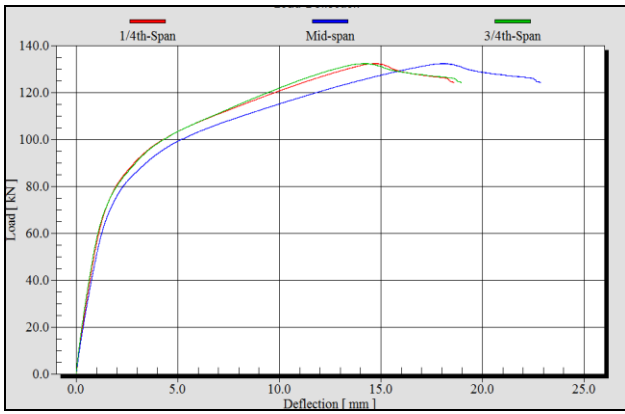

(a) OPC-A.1



(b) final cracking at ultimate load

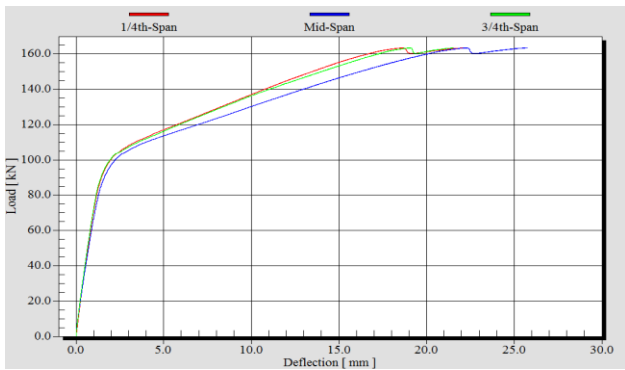

(c) OPC-A.2



(d) final cracking at ultimate load

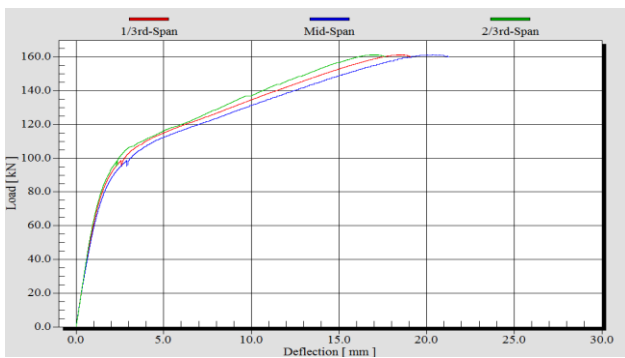

(e) OPC-B.1



(f) final cracking at ultimate load

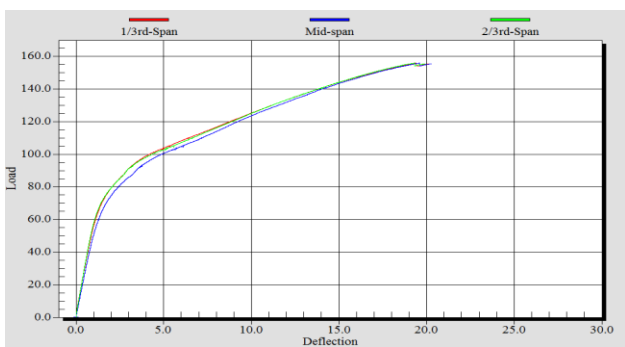

(g) OPC-B.2



(h) final cracking at ultimate load

Fig. 4 – Load vs. displacement of PSC beams under flexural testing and final cracking and concrete crushing at ultimate load

Table 4 –Flexural test results of PSC beams made of OPC and PPC

Beam Type	Cement Type	Up to first crack		Ultimate load		Modes of failure	P_u/P_y
		Load (kN) (P_y)	Deflection at mid-span (mm)	Load (kN) (P_u)	Deflection at mid-span (mm)		
OPC-A.1	OPC	80	2	133	18	Flexure-concrete compression	1.66
OPC-A.2		90	2	164	23		1.82
PPC-B.1	PPC	80	2	160	21		2.00
PPC-B.2		70	2	150	20		2.14



Fig. 5 – Fatigue testing arrangement

Minimum stress was maintained in order to prevent any possible movement of specimens at the support and to simulate the residual stress in concrete to a certain degree. The maximum stress in the loading was decided keeping in view the maximum stress encountered in general in the concrete during its service life. The age of the specimens at the time of testing was 28 days. For both types of cements, six cylindrical samples each were tested. Three cylinders were tested for fatigue and three were kept as controlled sample for both types of cements.

3.2.1.1 Test Results of Fatigue testing in compression of concrete cylinders

The test results of fatigue test indicated that there is no significant reduction in strength in concrete made with PPC and OPC when test is conducted for one million cycles with a maximum stress level of 70 percent on concrete grade M40 (See Table 5).

3.2.1.2 Fatigue testing in flexure of post-tensioned PSC beams

The minimum and maximum loads for the fatigue load range were fixed as 20 kN and 75 kN, respectively. Ultimate load testing was carried out on these beams after one million cycles of fatigue loading in the range. The loading and instrumentation arrangement for fatigue loading and subsequent ultimate load testing after one million cycles of loading were same as used for monotonic static

load testing. To conduct fatigue testing, the loading range of 20–75 kN for one million numbers of cycles at a frequency of 3 Hz was opted. Minimum load level was maintained in the order to prevent any possible movement of specimens at the support and to simulate the residual stress in concrete to a certain degree. The maximum load in the loading cycle was decided keeping in view the average load at first crack obtained during testing of beams in flexure and without application of load cycles. The maximum load application frequency of machine was 3 Hz. The deflections in beam and loading cycles are shown in Figs. 6 and 7. The total duration of fatigue load test was around 95 hours. To apply fatigue load on the beam, each specimen was initially loaded up to a magnitude of 75 kN and unloaded up to 20 kN at a frequency of 3 Hz by means of a servo-controlled hydraulic actuator. The upper and lower load limits of the cyclic loading were kept constant during the test period. Deflections at mid, one-third and two-third span, concrete strains in compression and tension locations were measured using LVDTs and electrical resistance strain gages continuously for entire duration of the test using the high precision data acquisition system. Throughout the fatigue load, the beam behavior (response) was observed for any initiation of cracks. The fatigue test was stopped after completion of one million cycles of loading. The test results are given in Table 6, and graphs and images are shown in Fig. 8.

Table 5 – Results of fatigue test for M40 Grade concrete: no. of cycles = 1 million; fatigue load= 70% of cylinder strength

Cement type	Crushing strength of cylinder (N/mm ²)	Fatigue load (kN)	Strength of cylinder after fatigue (N/mm ²)	Average strength of control specimens (cylinder not subjected to fatigue loading) (N/mm ²)
OPC	43.30	237.03	42.95	44.60
	45.70	251.10	44.60	46.07
	49.40	271.40	48.35	50.39
PPC	42.60	234.08	41.29	44.28
	46.40	254.96	45.98	48.35
	48.60	267.50	48.20	49.80

Table 6 – Flexural test results of PSC beams after fatigue cycles: OPC and PPC

Beam Type	Cement type	Up to first crack		Ultimate load		Modes of failure	P_u/P_y
		Load (kN) (P_y)	Deflection at mid-span (mm)	Load (kN) (P_u)	Deflection at mid-span (mm)		
OPC - C.1	OPC	90	2	150	22	Flexure (concrete compression)	1.67
OPC - C.2		75	2	165	22		2.20
PPC - D.1	PPC	90	3	158	20		1.76
PPC - D.2		90	3	160	20		1.78

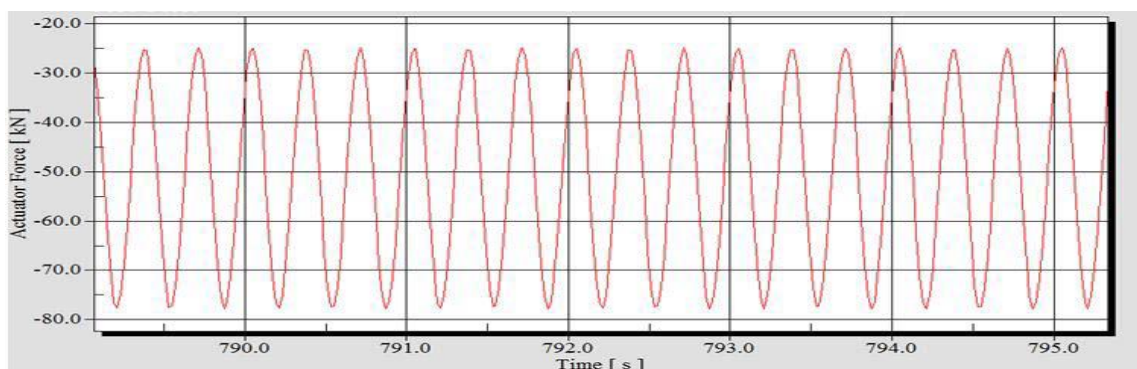

Fig. 6 – Cyclic loading at 3 Hz

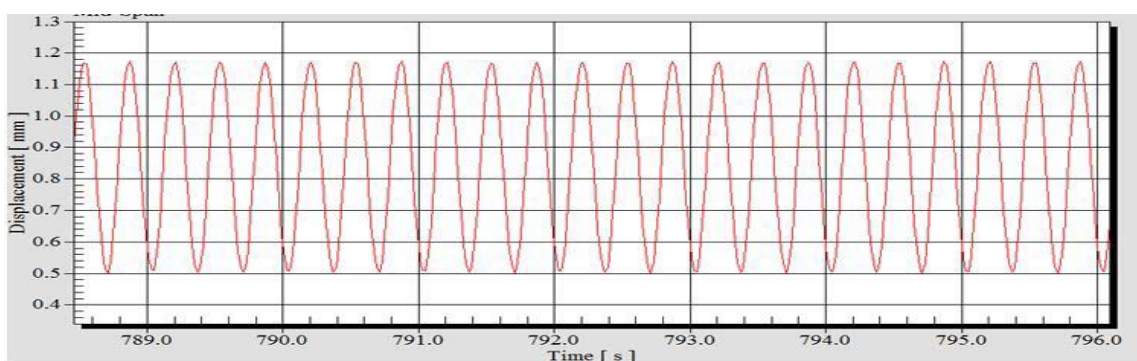
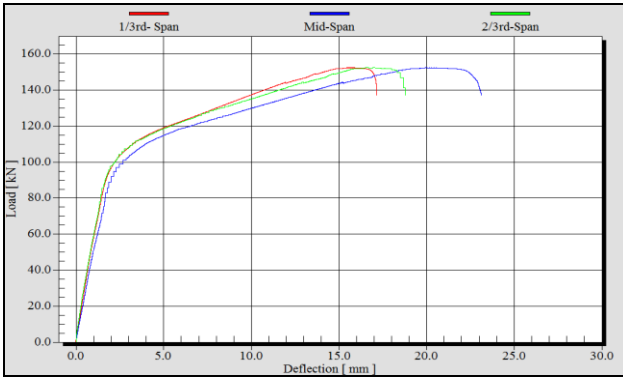

Fig. 7 – Deflection under cyclic loading

3.2.2 Test results of fatigue testing in flexure of post-tensioned PSC beams

After fatigue loading, beams were tested for flexure. The cracking load of all beams tested after fatigue is approximately equal to the cracking load of beams which were tested directly without fatigue load. This shows that the material of the beam after undergoing the fatigue load does not disintegrate and is intact. The beam failed in flexure with

crushing of concrete in the compression zone near the mid span. The deflection response of the beam is linear until first crack initiation and becomes nonlinear after the cracking. From the plots, it is noticed that the behavior of this beam after subjected to fatigue load, closely matched with the behavior of the beam tested under monotonic load without fatigue cycles.



(a) OPC-C.1

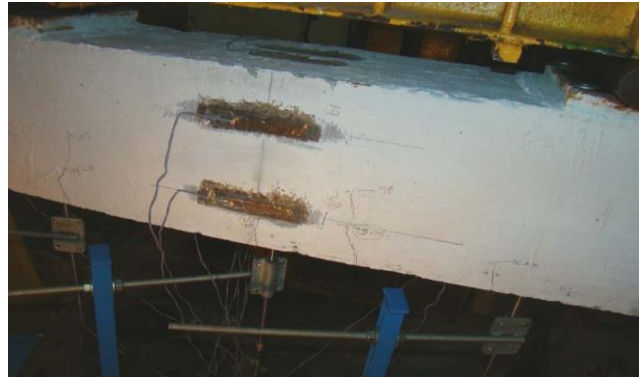

(b) final cracking at ultimate load

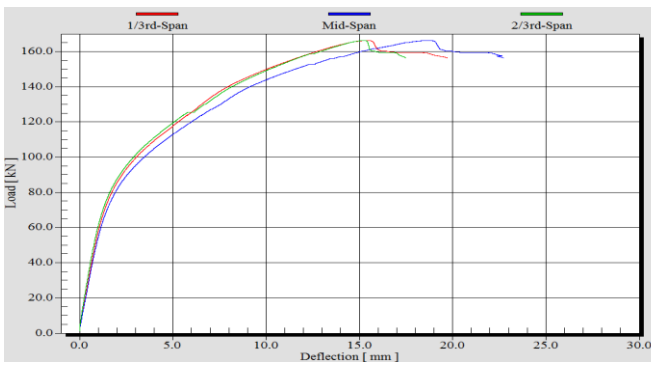

(c) OPC-C.2



(d) final cracking at ultimate load

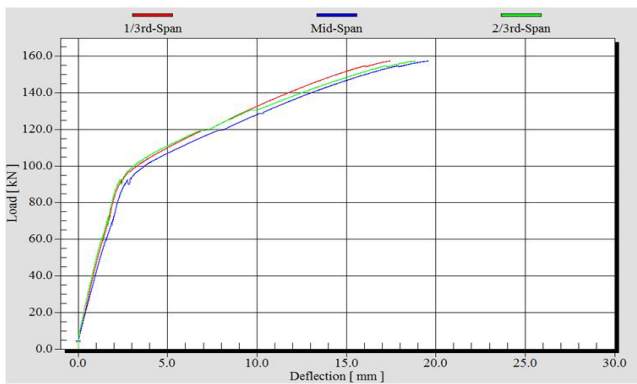

(e) PPC-D.1



(f) concrete crushing at top at ultimate load

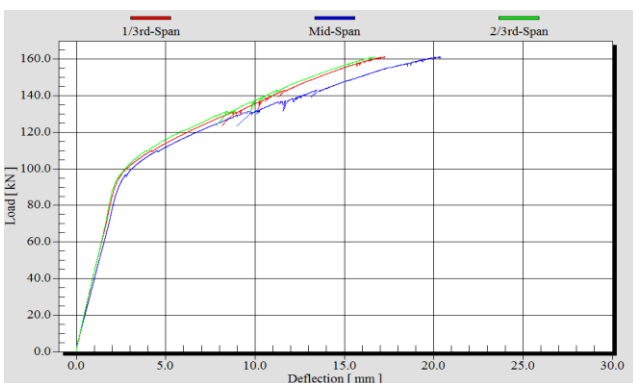

(g) PPC-D.2

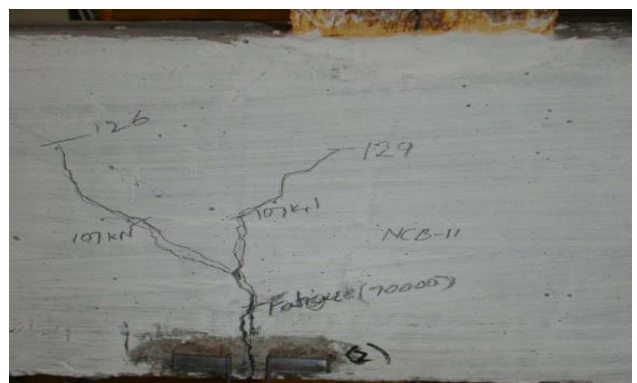

(h) final cracking at ultimate load

Fig. 8 – Load vs. displacement of PSC beams for flexural testing after fatigue and final cracking and concrete crushing at ultimate load

4. Conclusions

Based on the basic engineering properties studied earlier as well as in this study and fatigue studies, it is concluded that:

- (1) During flexural testing without fatigue, it was observed that the first cracking load was slightly lower in case of PPC but ultimate load was almost equal in the beams made using PPC and OPC.
- (2) As the ultimate load to load up to cracking load ratio (P_u/P_y) did not have any considerable change by applying million cycles of fatigue loading with respect to static loading, it can be inferred that the damage during the fatigue loading was minimal for the beams made using PPC and OPC.
- (3) From results, it can be inferred that the ultimate strength of PSC beams after fatigue observed was in same range as that of testing of PSC beams without applying fatigue load cycles for both beams made with OPC and PPC. Therefore, fatigue performance was same for prestressed beams for both OPC and PPC.
- (4) As the ultimate strength with and without fatigue were in same range for both OPC and PPC, it can be inferred that at the stress levels used in the study (i.e. about 40–50 percent of ultimate strength), the beams were approaching their fatigue limit as no or minimal decrease in strength was observed after one million fatigue cycles. The reason for this is that concrete fatigue strength is influenced by the range of cyclic loading and no. of cycles. In general, a decrease of maximum stress level and/or stress range enhances fatigue life of concrete, and that is why minimum or no fatigue damage was observed.

References

1. Tavio and Teng, S. (2004) "Effective Torsional Rigidity of Reinforced Concrete Members," *ACI Structural Journal*, 101(2), pp. 252-260.
2. Arora Vir Vikram; Singh Brijesh; Prakash Amit; and Ghatak Arup (2013) "Use of Portland Pozzolana Cement for RCC and Prestressed Concrete," *Proceedings of the 2013 NCB International Seminar on Cement and Building Materials*, New Delhi, India.
3. Jin-Keun Kim and Yun-Yong Kim (1996) "Experimental Study of the Fatigue behavior of High Strength Concrete," *Dept of Civil Engineering, Korea Advanced Institute of Science and Technology, Taejon, Korea*.
4. ACI Committee 215 report (1986) "Considerations for Design of Concrete Structures subjected to Fatigue Loading, ACI 215R-74," American Concrete Institute, Detroit.
5. M.K. Maroliya (2012) "Comparative Study of Flexural Behavior of Reinforced Concrete Beam and Prestressed Concrete Beam," *International Journal of Engineering Research and Applications (IJERA) ISSN: 2248-9622*, 2(6), pp. 230-233.
6. Jan Vorel; Mahendra Gattu; and Zdenek P. Bazant (2014) "Size Effect in Flexure of Prestressed Concrete Beam Failing by Compression Softening," *Dist. M.ASCE, American Society of Civil Engineers*.
7. V.V. Arora; Brijesh Singh; S.K. Mehta; and Suresh Kumar (2011) "Studies On Engineering Properties Of Plain Concrete Made With Portland Pozzolana Cement And Ordinary Portland Cement," *NCB International Seminar on Cement and Building Materials*, New Delhi, India.
8. BIS IS 456 (2000) *Plain and reinforced concrete-Code of Practice*, Bureau of Indian Standards, New Delhi, India.
9. BIS IS 1343 (2012) *Prestressed Concrete — Code of Practice*, Bureau of Indian Standards, New Delhi, India.
10. BIS IS 383 (1970) *Specification for Coarse and Fine Aggregates from Natural Sources for Concrete*, Bureau of Indian Standards, New Delhi, India.