

Technical Paper

Visual investigation method and structural performance evaluation for DEF induced damaged Indian Railway PC sleepers

Rajamurugan Sundaram*, Koji Matsumoto, Kohei Nagai and Anupam Awasthi

(Received: June 24, 2018; Accepted: November 21, 2018; Published online: January 04, 2019)

Abstract: Indian Railways uses pre-stressed concrete (PSC) sleepers for its tracks. In the recent years in north and central part of railways, premature cracks were observed in sleepers. Cracks were observed for sleepers 6 to 9 years after their manufacture. In this research, structural performance of damaged sleepers was evaluated in both material and structural level. For material level investigation, core samples were taken from the damaged sleepers. From the cores, reduction in static elastic modulus and compressive strength were observed for damaged sleepers when compared to undamaged sleepers. For structural level investigation, based on the level of the damage, sleepers were categorized into damaged and undamaged sleepers, and flexural test and shear test for sleepers were conducted. From the bending and shear test results, relationship between the crack pattern and capacity reduction in damaged sleepers was studied. In the flexural test, it was found out that more layers of longitudinal cracks in the central parts reduced its capacity up to 35% when compared to undamaged sleepers. Shear test results showed that it was very close to the minimum requirement for capacity of the sleepers.

Keywords: delayed ettringite formation (DEF), alkali silica reaction (ASR), sleeper, concrete.

1. Introduction

The main objective of railways is to provide safe transport for passengers. Indian Railways uses pre-cast pre-stressed concrete sleepers from factories for its track. Concrete sleepers are important part of railway track to hold the rail in the position and transfer the load to the supporting structure below. In northern and central part of the railways, these sleepers start cracking 6 to 9 years after their manufacture. Even unloaded sleepers, which are not used in the tracks, also get cracked. As per the recent survey conducted in the central part of India, in a 100-km railway track and out of 128,000 sleepers, 45,000 sleepers were damaged with premature cracking. This means, in this particular railway track of 100 km, almost 35% of the sleepers are damaged. The

damaged sleepers are replaced annually: when failure cracks at insert location is observed sleepers are replaced immediately. No clear investigation has been carried to find the current capacity of these damaged sleepers. This research aims to find out the structural performance of damaged sleepers based on the existing crack patterns in the sleepers. For this purpose of investigation, research was carried out to find out sleepers with different levels of damage. This problem is a potential threat to the Indian Railways and it affects the safety of the passengers travelling in trains.

In Indian Railways, high temperature more than 70°C has been recorded during steam curing in the manufacturing process of sleepers. This may cause Delayed Ettringite Formation (DEF) and be the main cause of these premature cracking. Research was conducted in the past study in Indian Railways to find out the cause of expansive damages in concrete sleepers, where it was found out the cause of these cracks were due to both DEF and Alkali Silica Reaction (ASR) [1]. The ASR is caused by the chemical reaction between cement alkali and reactive aggregate that generates expansive ASR gel. In DEF, dissolved ettringite under high temperature curing is reformed after the concrete hardening to cause expansive stress. Experimentation with German high early

Corresponding author Sundaram Rajamurugan is an Engineer at Sumitomo Mitsui Construction Co. Ltd.

Koji Matsumoto is a Project Assistant Professor at Institute of Industrial Science, The University of Tokyo, Tokyo, Japan.

Kohei Nagai is an Associate Professor at Institute of Industrial Science, The University of Tokyo, Tokyo, Japan.

Anupam Awasthi is a Deputy Chief Engineer at Construction Organization in Indian Railways, India.

strength cement concluded that delayed expansion occurs when specimens were cured above 80°C [3]. Boundary temperature conditions for occurrence of DEF were between 60°C and 70°C [4]. To understand the DEF a holistic approach for late sulphate release, micro-cracking, and exposure to water was proposed [5]. Cement composition (alkalis, C₃S, C₃A, SO₃, and MgO) and fineness also influence the effect of DEF [2]. Typical crack patterns observed in the sleepers are shown in Fig. 1. Map cracks are observed at the ends and longitudinal cracks are observed at the midspan. In the past research of premature cracking, similar problems were observed in other parts of the world. In 2004, prestressed monobloc concrete sleepers placed in Portugal had shown premature cracking [6]. Sleepers manufactured in the years between 1992 and 1996 in Sweden have started to deteriorate and cracks were observed in sleepers [7]. As per a report in Finland 20,000 sleepers are replaced every year [8]. Distress in prestressed concrete sleepers was observed in eastern coast of United States [9]. It was predicted that causes of these cracks could be either DEF or ASR. From all these research, it is observed that damaged sleepers are huge in number and it is not possible economically to replace all the sleepers immediately. For rational and efficient maintenance, it is essential to set priorities for replacement considering the structural performances of sleepers. However, the past research including the authors study do not sufficiently clarify structural performances [1]. For this purpose of investigation, sleepers with various degrees of damages were selected to study the crack patterns. Material level testing and structural level testing were conducted in the sleepers to find out the current damage conditions of the sleeper. For material testing, core samples were taken from the damaged and undamaged sleepers, where compressive strength and static elastic modulus were found from the compressive test. For structural level investigation, crack patterns in the damaged sleepers were studied where map cracks were observed at the end of the sleepers and longitudinal cracks at the central part of the sleepers. Side view and top view of the damaged sleepers are shown in Fig. 1. Cracks are located at the insert location of the sleeper, which is a failure crack in the sleepers. Based on the level of damage, cores and sleepers were collected from the damaged and undamaged sleepers. Structural level testing was also conducted on both undamaged and damaged sleepers, where flexural test and shear test were conducted on the damaged and undamaged sleepers to find out the current capacity of the sleepers. Existing crack patterns from the damaged sleepers were studied and failure pattern was analyzed. The relationship between existing crack patterns and

capacity reduction in damaged concrete sleepers was studied.

Sleeper are placed on ballasted track bed as shown in Fig. 2. This ballast track bed acts as an elastic bed and transfer the load coming from sleeper to wider area of formwork. This formation is earthen embankment and its not bonded to concrete structure.

2. Proposal of visual inspection method

Visual inspection was conducted. Based on the damages observed in the sleepers, sleepers were classified into two categories such as Damaged and Undamaged sleepers (See Table 1). Within damaged and undamaged sleepers, sleepers were further classified into five categories. Undamaged sleeper's two categories were Undamaged new and Undamaged old. Sleepers in these categories did not have any visual cracks. Damaged sleepers were categorized into three categories such as Mild, Moderate and Severe damage. In Mild damaged sleepers edge cracks were observed in the sleepers, whereas in Moderate damaged sleepers one longitudinal crack was observed in the center of the sleepers. In Severe damaged sleepers, more than 2 to 3 longitudinal cracks were observed in the center.

Description of these cracks with crack widths is shown in Table 1. Typical view of these crack patterns is shown in Fig. 11. Cracks typically occur around 6 to 9 years after their manufacture. The ballast profile and crack sequence are shown in Figs. 2 and 3, respectively. When sleepers are in service, i.e. installed condition on track, first cracks are usually seen on the side face of the sleeper. The side face is covered with ballast and cracks are visible only after opening the ballast. In later stages cracks are also seen on the top surface of the sleeper. Ultimately failure occurs near the inserts [1].

Indian Railways uses M55 grade sleepers for its tracks (See Table 2). 3 ply of 3 mm high tensile strength strands are used in sleepers (See Fig. 4). According to the specification, each reinforcing strand is to be tensioned with initial force of 27 kN. Typical tendon profile and cross section of sleepers are shown in Fig. 4.

SEM analysis was conducted in the past study from concrete samples collected from Indian Railways, where presence of DEF from the concrete samples was observed (See Fig. 5). In order to find the effect of ASR in concrete, the authors also conducted the chemical analysis. It was found from the chemical analysis that alkali content in cement samples was greater than 5 kg/m³ (Table 3). Whereas as per Japanese standards, alkali amount should not exceed more than 3 kg/m³. This high alkali content in samples also promotes ASR.

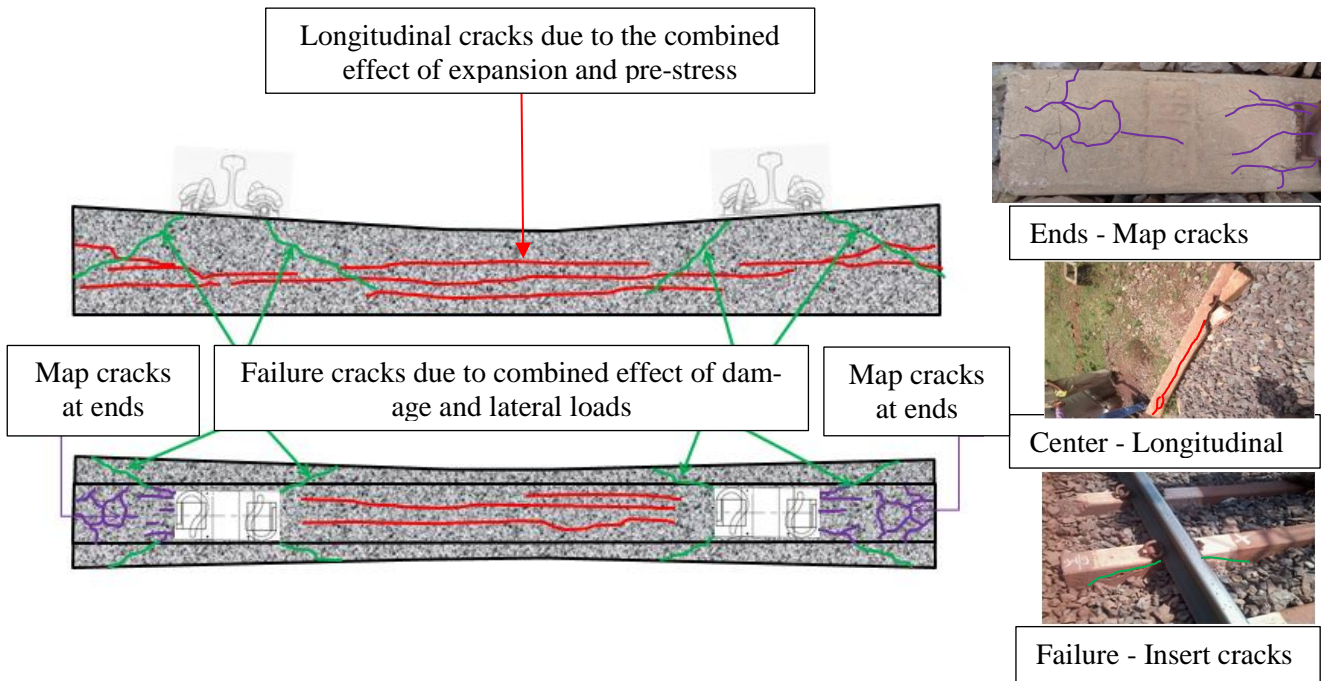

Fig. 1 – Typical cracking pattern observed in the sleeper of Indian Railways

Table 1 – Description of damage categories

Category	No. of sleepers	Cracks		
		Left side	Central part	Right side
Undamaged new	3	No cracks	No cracks	No cracks
Undamaged old	3	No cracks	No cracks	No cracks
Mild damage	2	1 mm cracks	1 mm cracks	No cracks
Moderate damage	3	1 mm cracks	1 layer of 1-2 mm cracks	1-2 mm cracks
Severe damage	4	1-3 mm cracks	2 to 3 layers of 2-3 mm cracks	1-2 mm cracks

Table 2 – Concrete mix proportions in sleepers

Coarse aggregate, CA1 (20 mm)	981.49 kg (50.50%)
Coarse aggregate, CA2 (20 mm)	420.64 kg (21.50%)
Fine aggregate, FA	546.28 kg (28.00%)
Cement (53-S)	445.50 kg/m ³
Admixture	2.227 kg (0.5%) of cementitious material
Water	142.56 Liters
W/C ratio	0.32
A/C ratio	4.373

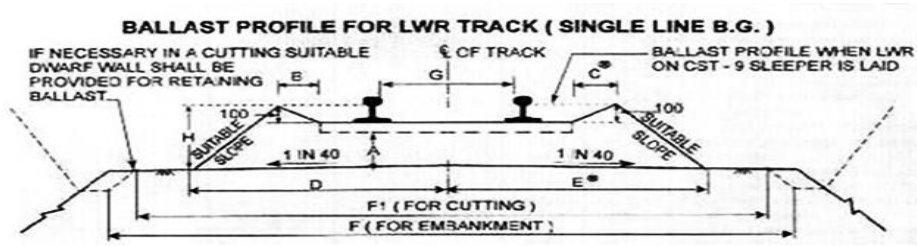
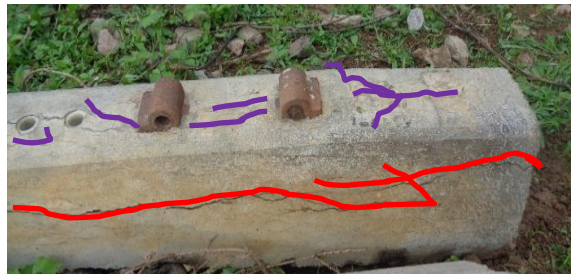

Fig. 2 – Ballast profile track slab



(a) First Step (Cracks at side face) (b) Second Step (Cracks visible on top surface)



(c) Third Step (Cracks near insert location)

Fig. 3 – Crack sequences

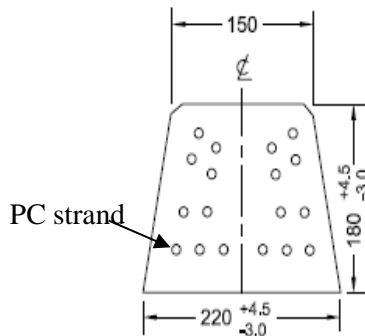

(a) Cross section of sleepers (unit: mm)



(b) 3 x 3mm wire strands

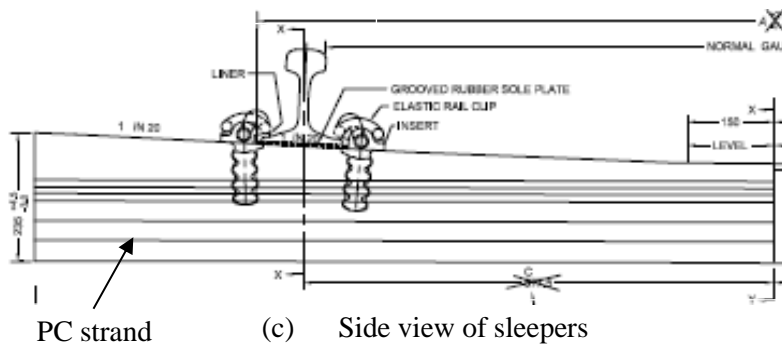

(c) Side view of sleepers

Fig. 4 – PS tendon profile

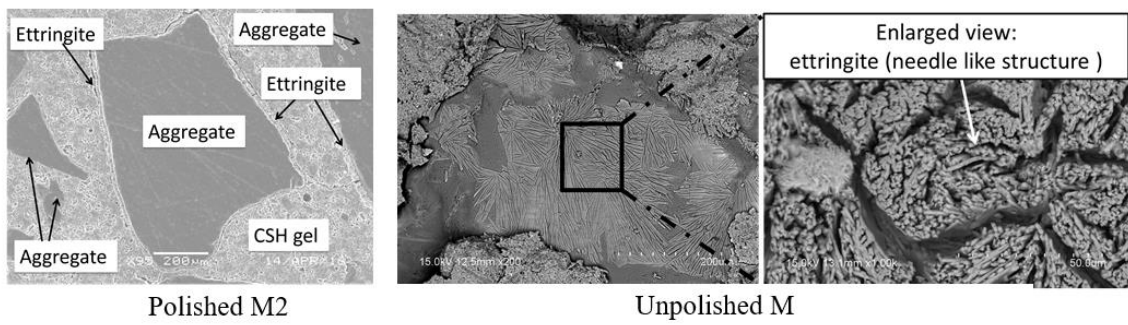
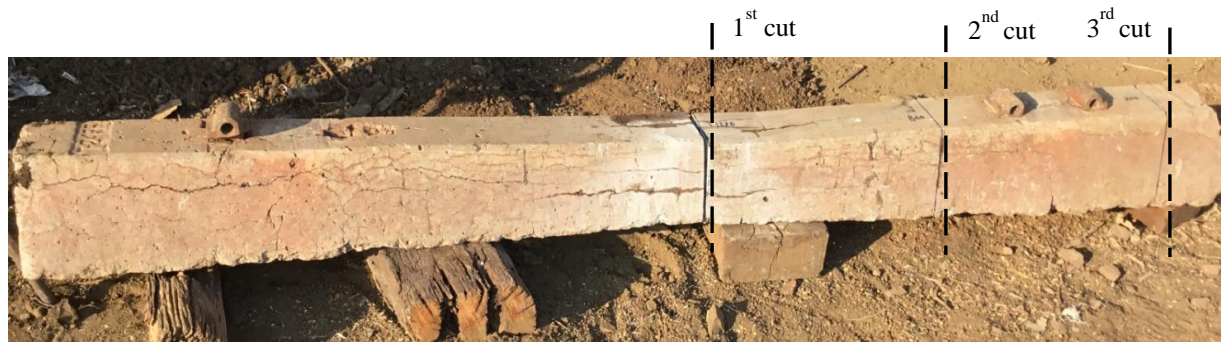

Fig. 5 – Presence of DEF in concrete samples [1]

Table 3 – Chemical analysis results in cement samples

Factories	Component analysis result of cement (mass %)			Alkaline amount (kg/m ³)
	Na ₂ O	K ₂ O	Na ₂ O eq.*	
1st Factory	0.27	1.28	1.11	5.03
2nd Factory	0.27	1.30	1.13	5.11
3rd Factory	0.27	1.28	1.11	5.03
Average	0.27	1.29	1.12	5.07



(a) Typical side view of Severe damaged sleeper

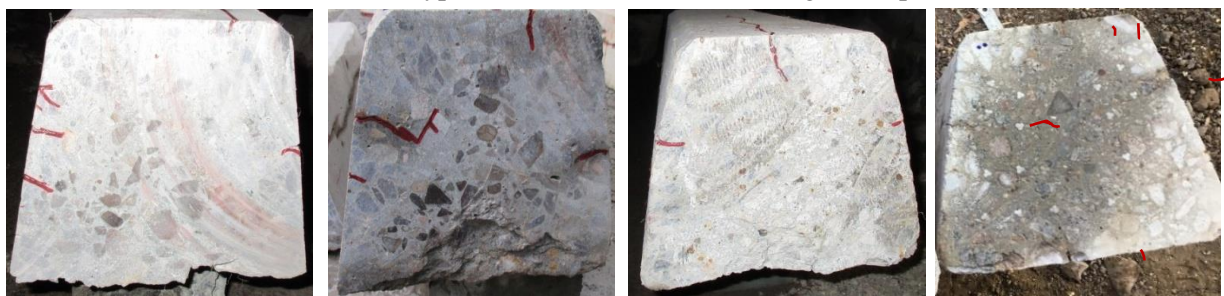

(b) Mild damage

(c) Moderate damage

(d) Severe damage

Fig. 6 – Cut cross section in sleepers

SEM analysis was conducted in the past study from concrete samples collected from Indian Railways, where presence of DEF from the concrete samples was observed (See Fig. 5). In order to find the effect of ASR in concrete, the authors also conducted the chemical analysis. It was found from the

chemical analysis that alkali content in cement samples was greater than 5 kg/m³ (Table 3). Whereas as per Japanese standards, alkali amount should not exceed more than 3 kg/m³. This high alkali content in samples also promotes ASR.

3. Internal crack pattern and tests of core samples

3.1 Cross section cut in sleepers

Sleepers were cut to find whether cracks have infiltrated inside the sleepers. Sleepers were collected from both damaged and undamaged sleepers (See Fig. 6), where manufacturing year of sleeper is also mentioned (See Table 4).

Except “Severe damaged sleeper” where three sleepers were taken for cross section cut, in rest of the categories only a sleeper was cut. Typical side

view of cross section cut is shown in Fig. 6(a), where three cuts were made on each sleeper. Critical cross sections based on the category with more cracks are shown in this Fig. 6. For both undamaged new and undamaged sleepers no cracks were observed inside the sleepers, crack infiltration up to 20 mm was only observed in the sleepers and cracks did not infiltrate fully inside the sleepers. It is observed from the study that DEF expansion occurs nonuniformly and only the inner portion is expanded, outer side is put in tension in the circumferential direction as we observed in the ring tension behavior, resulting in large cracks only in the outer side of the sleepers.

Table 4 – List of all the specimens used for cross section cut

Category	Manufacture year	No. of sleepers	Crack width		
			Left side	Central part	Right side
Undamaged new	2015	1	No cracks	No cracks	No cracks
Undamaged old	1986	1	No cracks	No cracks	No cracks
Mild damage	2006	1	1 mm cracks	1 mm cracks	No cracks
Moderate damage	2006	1	1 mm	1 layer of 1-2 mm	1-2 mm
Severe damage-I	2002	1	1-2 mm	3 layers of 2-3 mm	1-2 mm
Severe damage-II	2006	1	1-2 mm	3 layers of 2-3 mm	1-2 mm
Severe damage-III	2002	1	1-2 mm	3 layers of 2-3 mm	1-2 mm

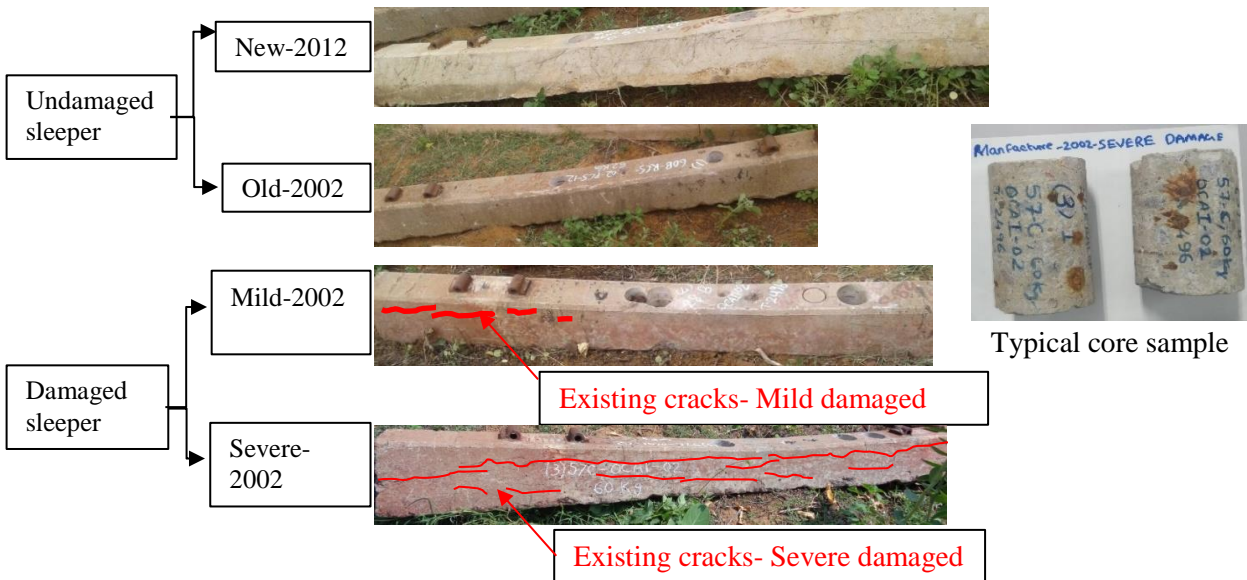

Fig. 7 – Side view of damaged and undamaged sleepers for cores samples

Table 5 – Cores samples for compressive test

Category	Damaged sleeper	Manufacturing year	Number of cores
Undamaged	New	2015	2
	Old	2002	2
Damaged	Mild	2002	2
	Severe	2002	2

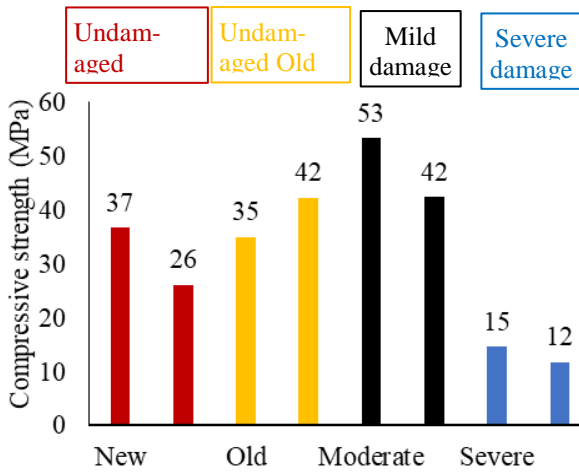

Fig. 8 – Compressive strength of core samples

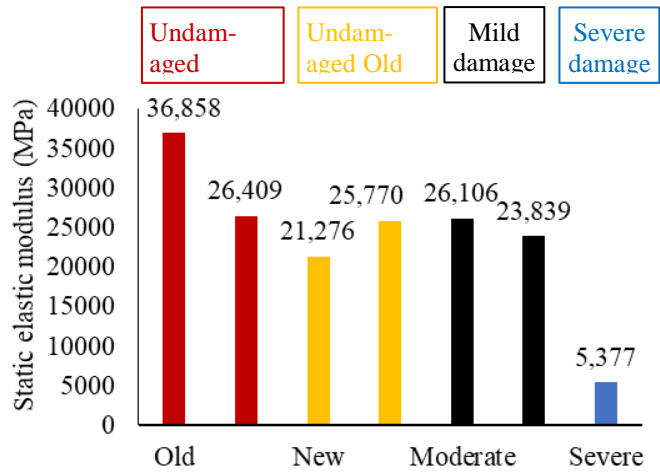

Fig. 9 – Static elastic modulus of core samples

Table 6 – Number of tested sleepers based on manufacturing year

Manufacturing year	Number of sleepers
2015	3
1986	3
2006	3
2006	3
2002	3

Table 7 – Number of tested sleepers based on level of damage

Category	Number of sleepers and manufacturing year	
Undamaged new	3 Nos. in 2015	
Undamaged old	3 Nos. in 1986	
Mild damage	1 Nos. in 2006	1 Nos. in 2002
Moderate damage	3 Nos. in 2006	
Severe damage	2 Nos. in 2006	2 Nos. in 2002

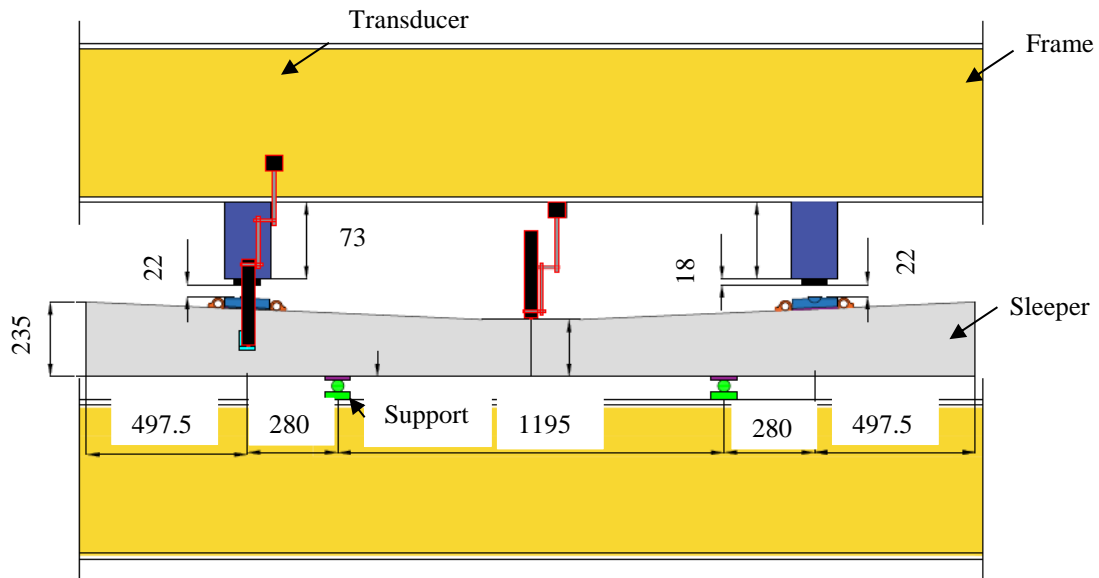

Fig. 10 – Schematic view of flexural test arrangement (Dimensions in mm)

3.2 Compressive test of core sample

Cores were collected from both damaged and undamaged sleepers for compressive test (See Fig. 7), where manufacturing year of sleeper is also included (See Table 5). One typical view of core sample is shown in Fig. 7. Compressive strength and static elastic modulus were obtained from the compressive test of core samples. From the compressive test results, peak load of core samples was obtained

and compressive strength of core samples were calculated. It was observed that average compressive strength for several damaged specimens was 13.2 MPa and whereas average compressive strength of 53 MPa was observed for Mild damaged core. Figure 8 shows the compressive strength results of the core samples. Static elastic modulus was calculated and the results are compared in Fig. 9. Minimum static elastic modulus of 5 GPa was recorded in the Severe

damaged core, whereas maximum static elastic modulus is recorded in undamaged old core of about 37 GPa (Fig. 8). Even though no visual cracks were observed in the cores, reduction in material strength up to 75% was observed in Severe damaged sleepers when compared to Mild damaged sleepers. It was

found from the study that outer crack is an indication to show the capacity reduction in sleepers, but this is not the main reason for capacity reduction in cores. Main reason is concrete is affected in material level due to expansion in concrete due to DEF and ASR.

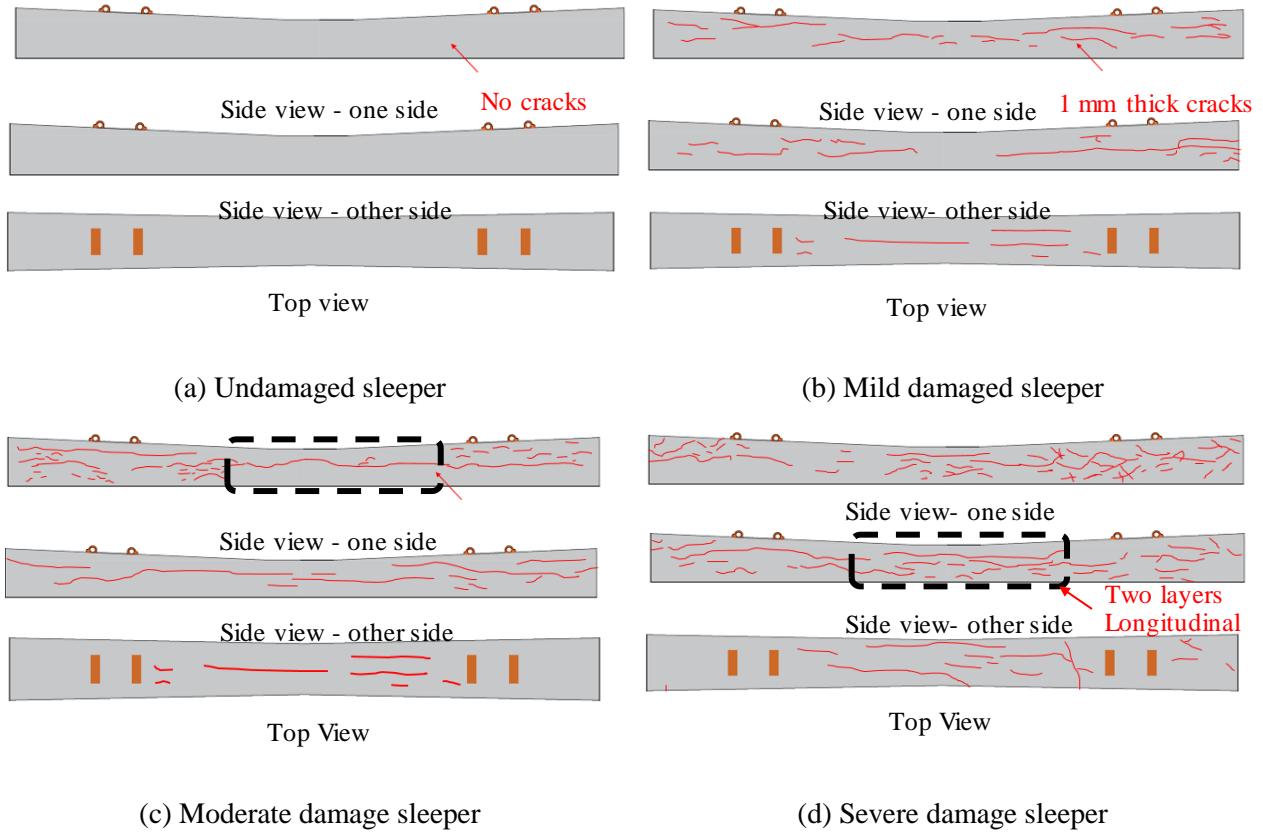

Fig. 11 – View of crack patterns of sleepers before loading

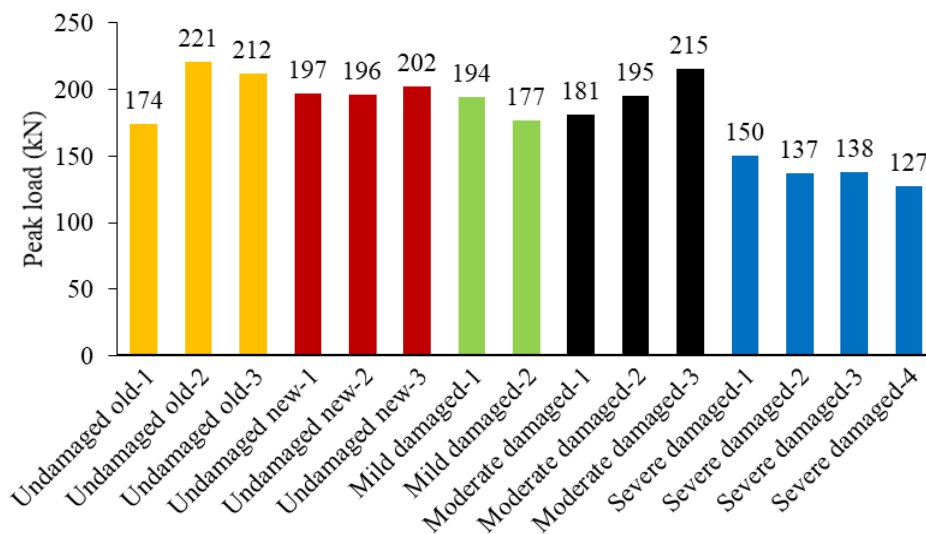

Fig. 12 – Result of flexural test

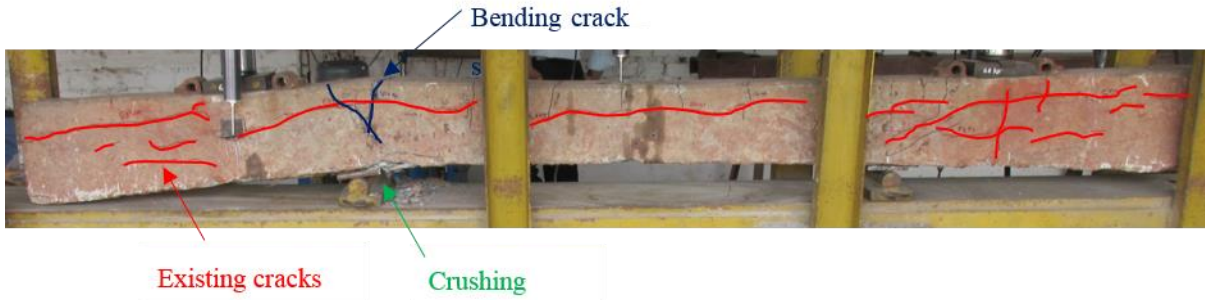

Fig. 13 – Typical view of sleeper after failure (Severe damaged)

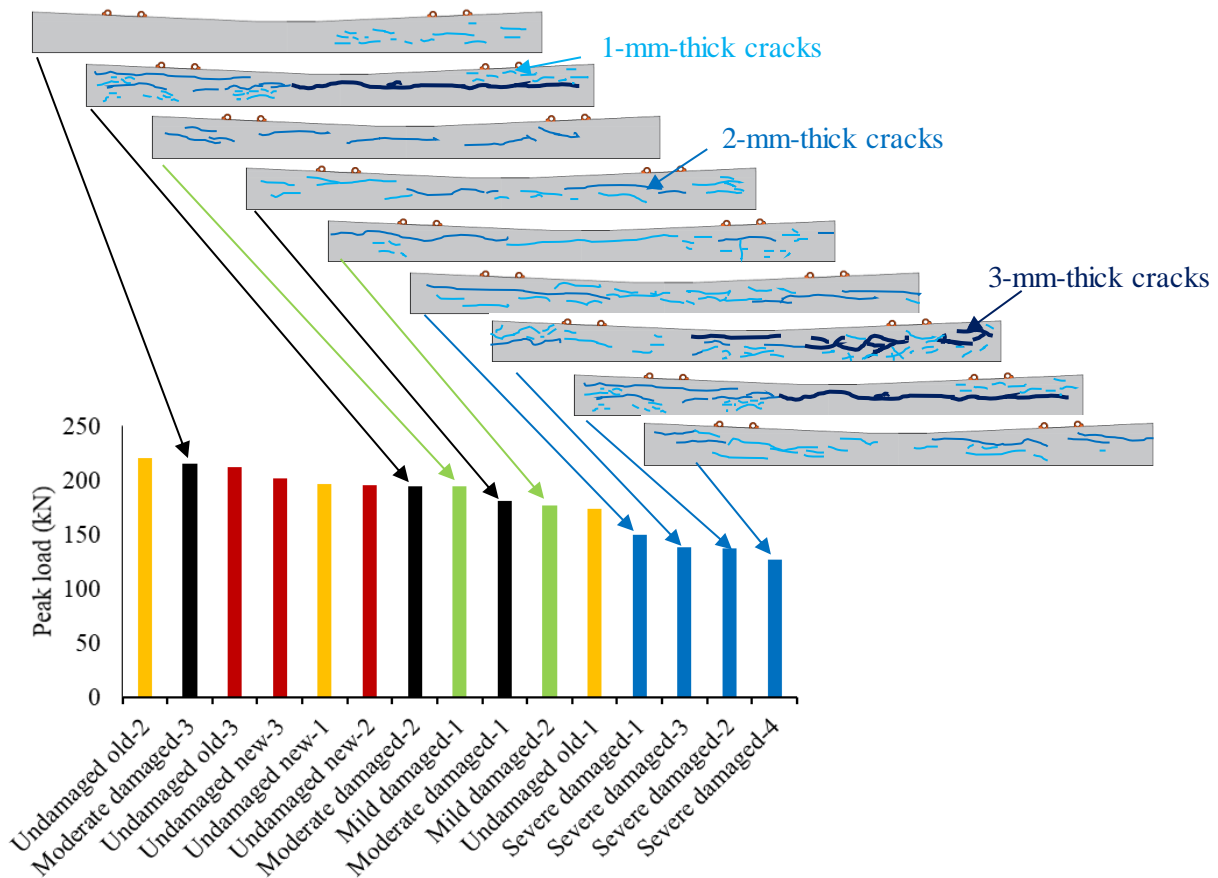

Fig. 14 – Side view – comparison of capacity in damaged sleeper

4. Loading test for sleepers

4.1 Flexural test

Fifteen sleepers with different levels of damage were collected from Indian Railways (See Table 6). Within these 15 sleepers, sleepers were further categorized into five categories such as “Undamaged new”, “Undamaged old”, “Mild damage”, “Moderate damage” and “Severe damage” based on the level

of damage (See Table 7). Flexure test was conducted to find out the flexural capacity of the sleepers (See Fig. 10). Transducers were fixed at the loading points and at the center part of the sleeper to find midspan deflection. Sleepers were loaded in flexure and allowed to be loaded until the failure is observed from the sleeper [1].

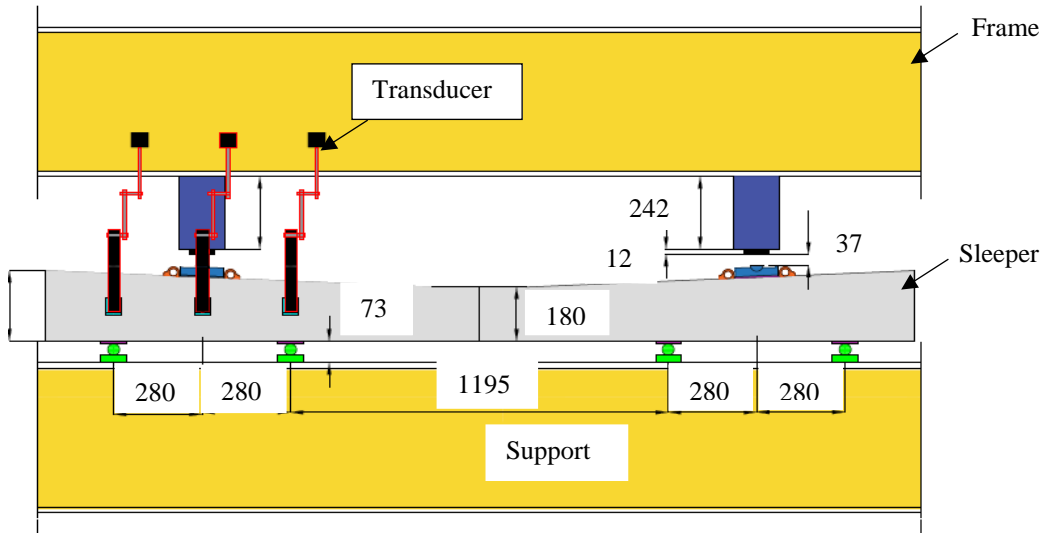

a) Typical shear test arrangement on one side

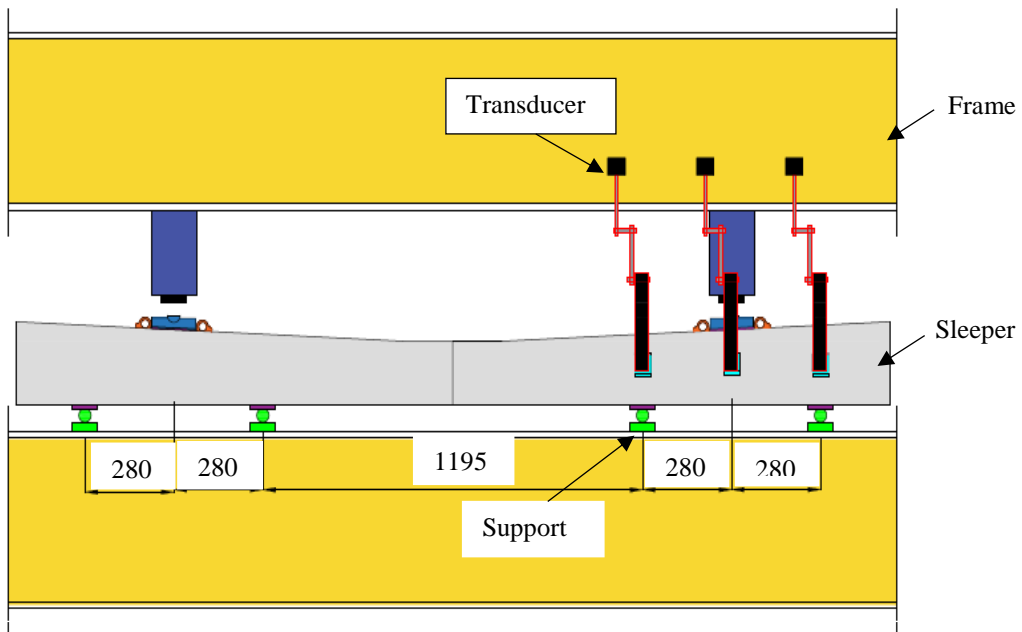

b) Typical shear test arrangement on the other side

Fig. 15 – Schematic shear test arrangement

Table 8 – Number of tested sleepers based on level of damage for shear test

Category	Manufacturing year	Number of sleepers
Undamaged new	2015	1
Severe damage	2002	3



a) Undamaged New



b) Severe Damaged Sleeper 3 mm cracks

Fig. 16 – Typical view of crack patterns of sleepers

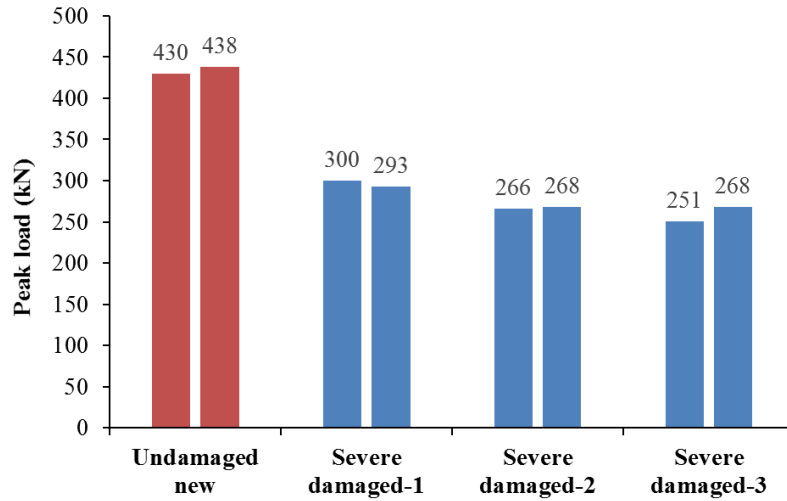

Fig. 17 – Result of shear test

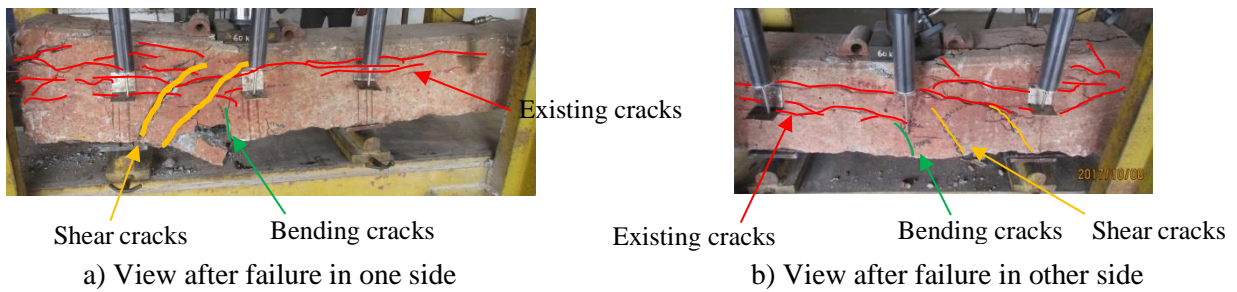

Fig. 18 – Typical view of sleeper after shear failure

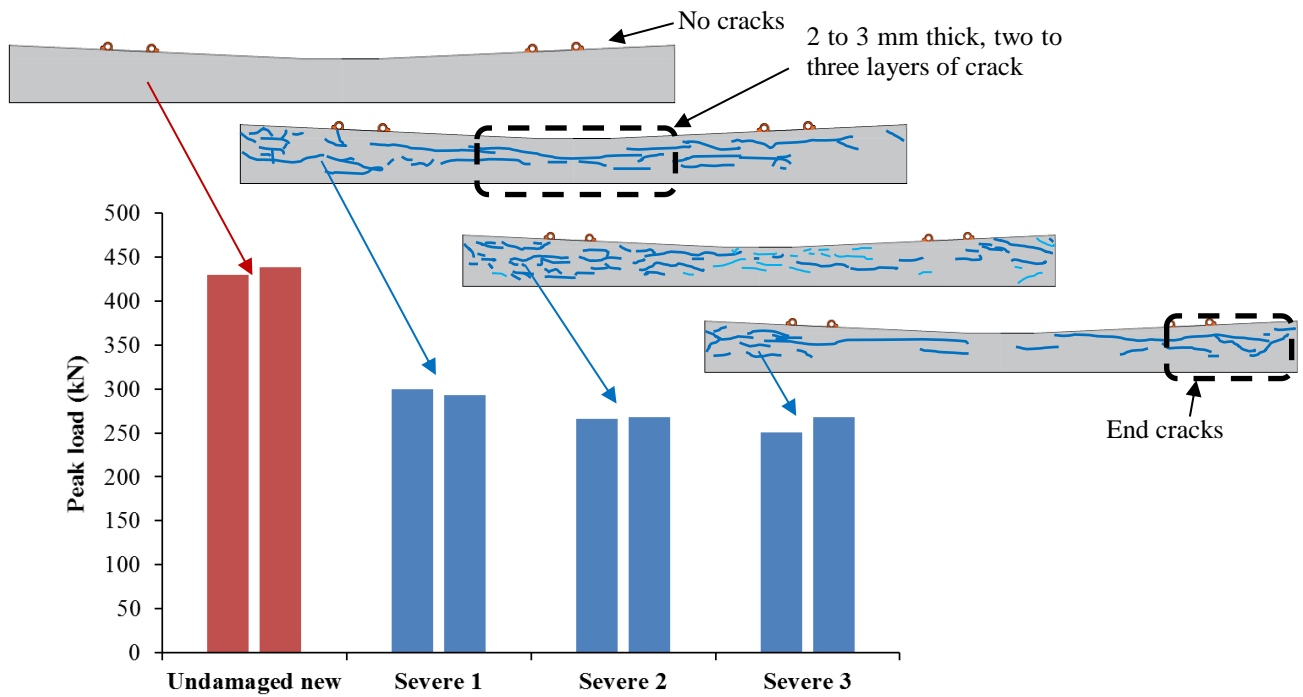

Fig. 19 – Existing crack patterns and shear test results

4.1.1 Results of flexure test

From the flexure test results, peak loads were obtained for all categories of sleepers (See Fig. 12). It is clearly seen that not only peak load but also stiffness is significantly reduced in the case of severe damaged sleepers. One of the typical views of sleeper after the failure is shown in Fig. 13. Mode of failure is supposed to be flexural compression failure which occurs before yielding of PC strands.

4.1.2 Relationships between flexural capacities and visible crack pattern

From the flexural test results, it shows that Severe damaged sleepers show capacity reduction (See Fig. 14). Average peak load of Severe damaged sleeper is 56% capacity reduction. Average peak load of Moderate damaged sleeper is same as Undamaged old sleepers, but in one of the cases Moderate damaged sleeper shows 8% capacity reduction. Average peak load of Mild damaged sleeper is 7% less than Undamaged old sleepers, but in the cases Mild damaged sleeper shows 12% capacity reduction. By comparing the results of both Undamaged old and new sleepers less than 2% difference was observed. If 2 to 3 layers of longitudinal cracks were observed in the central part of sleeper these cracks reduce the capacity of the sleeper.

Minimum peak load as per Indian standards for flexural test is 60 kN. Even though severe damaged sleeper showed reduction in peak load, still the minimum peak load observed in these sleepers was 127 kN. Therefore, sleepers are safe in flexure. The evaluation method in which damage level is classified are appropriate. The evaluation method in which damage level is classified are appropriate, where damage sleepers show lesser capacity compared to undamaged sleepers.

4.2 Shear test

Shear test was also conducted for sleepers. Illustrated view of shear test arrangement is shown in Fig. 15. Transducers were fixed near the loading points and at the central part of the sleeper to find midspan deflection. Shear test was conducted on one side first and after completion the test was repeated over the other side on the same sleeper. Sleepers were categorized into “Undamaged new” and “Severe damage” (See Table 8). Typical view of these categories of sleepers is shown in Fig. 16.

4.2.1 Results of shear test

From the shear test results, peak loads were obtained from Undamaged new and Severe damaged sleeper (See Fig. 17). View of the sleeper after failure is shown in Fig. 18. Shear capacity and member stiffness in severe damaged sleepers significantly reduced as observed in the flexure tests.

4.2.2 Relationship between shear capacities and visible crack patterns

Figure 19 shows the existing crack patterns available in sleepers. Average peak load of Severe damaged sleeper is 36% less than the Undamaged old sleeper, but in one of the cases Severe damaged sleeper shows 42% capacity reduction. Minimum requirement for the peak load as per Indian standards is 230 kN. In one of the cases peak load is 250 kN and this is close to the minimum requirement for the peak load. Cracks were observed in severe damage sleeper, where more layers of end cracks and more layers of longitudinal cracks were observed in damaged sleepers. It indicates that shear capacities are also correlated.

Future deteriorations such as corrosion in the mild and moderate damage sleepers seem not to be a significant issue since the surrounding environment of the sleepers is rather mild (no chlorides, no sulfate, etc.), therefore verifications of durability performances are not an emergent problem. However, considering that environmental conditions in the other regions are different from those in this study, investigation on the durability performance of damaged sleepers is also an important issue in the future.

5. Conclusions

In this study, the evaluation method for damage level by visual inspection was proposed for damaged PC sleepers of Indian Railways. The proposed evaluation method was validated by comparing results on the material properties and structural performances. As a result, following conclusions are obtained.

- (1) The evaluation method in which the damage level is classified into “no damage”, “mild damage”, “moderate damage” and “severe damage” based on the width and number of cracks observed on the outer surface of OC sleepers was proposed.
- (2) The PC sleepers were cut and the inner crack patterns were investigated. As a result, the cracks do not infiltrate to the deeper region even in the case of “severe damage”. It indicates that the expansion caused by DEF and ASR is not uniform but it occurred only in the inner region. Thus, crack patterns observed on the outer surface are affected by not only amount but also spatial distribution of the expansion strain.
- (3) Compressive tests of core samples taken from the damaged PC sleepers were conducted. As a result, compressive strength and elastic modulus of the concrete are significantly reduced especially in the cases of “severe damage”. DEF

and ASR affect the mechanical properties in the material level.

- (4) Loading tests of PC sleepers were conducted. As a result, both flexural and shear capacities were significantly decreased in the cases of “severe damage”. Especially, shear capacities of the “severe damage” cases closed to the minimum requirement level of Indian Railways, indicating that replacement of those sleepers is an urgent issue. In addition, it was confirmed that there is a good correlation between the structural performances and damage levels, indicating that the evaluation method for damage level proposed in this study is appropriate to determine the priority for the replacement.
 - (5) Mild and Moderate damaged sleepers can be continued to use by Indian Railways. When compared material strengths and capacity of the Mild and Moderate damaged sleepers to those of the undamaged new core samples, significant reductions were not noticed. However, considering the further damage progress in the future, it is recommended that damaged sleepers are replaced from severer ones.
 - (6) Due to the presence of high alkali content (5 %) in cement samples. Recommendation has been made to Indian Railways to maintain alkali content to less than 3 %.
6. Santos, S. (2004) “Diagnosis and Prognosis of Portuguese Concrete Railway Sleepers Degradation – a Combination of ASR and DEF.” 13th International conference on AAR, Norway.
 7. Hakan T. (2006) “Assessment of Fatigue Resistance and Strength in Existing Concrete Structures,” Doctoral thesis, ISBN 978-91-85685-03-5, pp. 133-148.
 8. Tepponen, P.; and Eriksson, B. (1987) “Damages in Concrete Sleepers in Finland,” Nordic Concrete Research, 6, pp. 199-209.
 9. Mielenz, R. C.; Marusin, S. L.; Hime, W G.; and Jugovic, Z. T. (1995) “Investigation of prestressed concrete railway tie distress,” Concrete International, 17(12), pp. 62-8.

References

1. Awasthi, A.; Matsumoto, K.; Nagai, K; Asamoto, S.; and Goto, S. (2017) “Investigation on Possible Causes of Expansion Damages in Concrete – a Case Study of Sleepers in Indian Railways,” Journal of Asian Concrete Federation, 3(1), pp. 49-66.
2. Sahu, S. and Thaulow, N. (2004) “Delayed Ettringite Formation in Swedish Concrete Railroad Ties,” Cement and Concrete Research, 34, pp. 1675-1681.
3. Ghorab, H. Y.; Heinz, D.; Ludwig, U.; Mesken-dahl, T.; and Welter, A. (1980) “On the stability of calcium aluminate sulphate hydrates in pure systems and in cements”, 7th Intl. Congr. Chem. Cem., Vol IV, pp. 496-503.
4. Hanehara, S. and Oyamada, T. (2010) “Reproduction of delayed ettringite formation (DEF) in concrete and relationship between DEF and alkali silica reaction,” Monitoring and Retrofitting of Concrete Structures- B. H. Oh, et al. (eds), Korea Concrete Institute, Seoul, ISBN 978-89-5708-181-5.
5. Collepardi, M. (2003) “A state-of-the-art review on delayed ettringite attack on concrete,” Cement and Concrete Composites, 25, pp. 401-407.